

SPECIAL ATTACHMENTS FOR SM AND D MODELS

Base plate

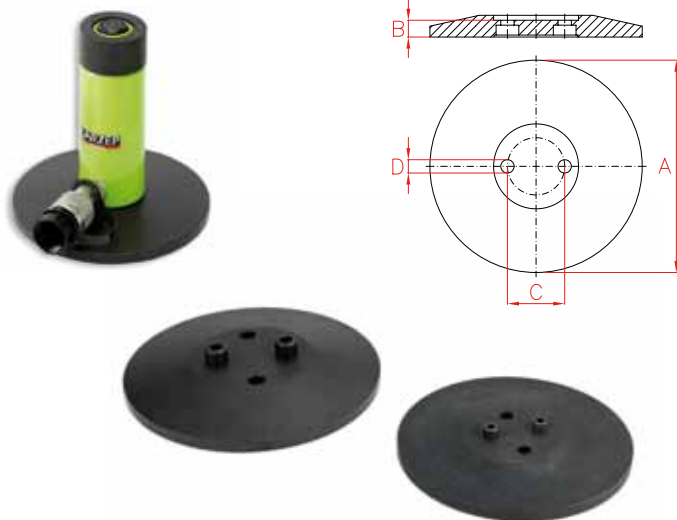

	Model	A	B	C	D	Weight
Tn	LARZEP	mm	mm	mm	mm	kg
5	SM005P	150	15	25	7,0	2,2
10	SM010P	180	15	39	8,5	4,1
15	SM015P	180	15	47	10,0	4,1
23	SM023P	215	17	58	13,5	4,9
30	SM030P	215	17	66	13,5	4,9
50	SM050P	305	22	95	13,5	13,1
75	SM075P	350	32	115	21,0	25,6
100	SM100P	400	40	139	21 (4)	29,3

Mounting block

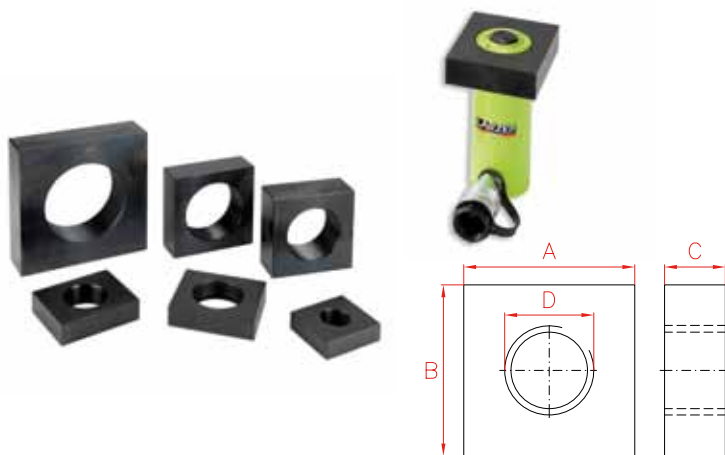

	Model	A	B	C	D
Tn	LARZEP	mm	mm	mm	UN
5	SM005B	76	90	25	1 1/2" - 16
10	SM010B	90	114	30	2 1/4" - 14
15	SM015B	100	114	30	2 3/4" - 16
23	SM023B	127	127	45	3 5/16" - 12
30	SM030B	135	135	45	3 7/8" - 12
50	SM050B	200	200	55	5" - 12
100	SM100B	330	330	55	6 7/8" - 12

Collar toe

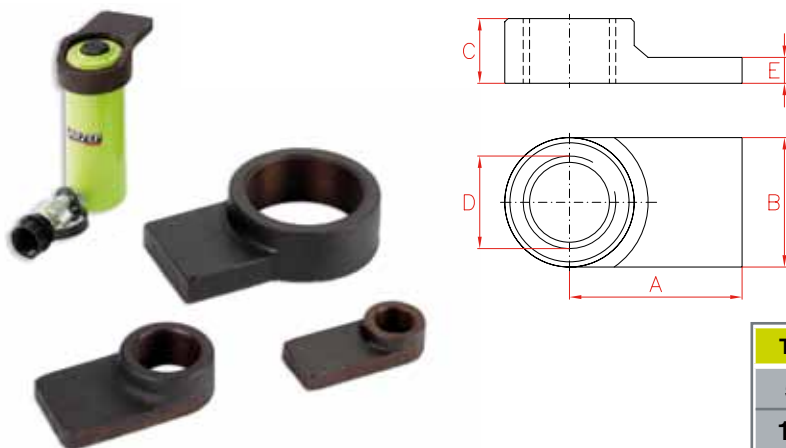

When using this accessory do not exceed 350 bar.



	Model	A	B	C	D	E
Tn	LARZEP	mm	mm	mm	UN	mm
5	SM005U	71	40	30	1 1/2" - 16	11
10	SM010U	79	60	37	2 1/4" - 14	12
23	SM023U	105	80	40	3 5/16" - 12	20

Clevis eye body

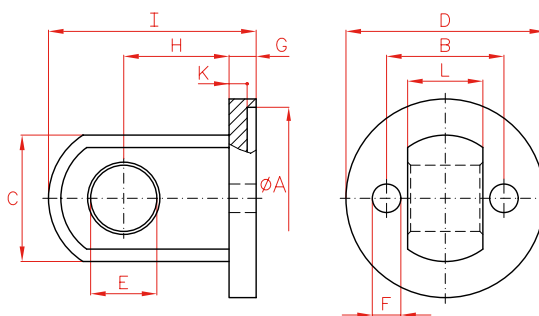

	Model	A	B	C	D	E	F	G	H	I	K	L
Tn	LARZEP	mm	mm	mm	mm	mm	mm	mm	mm	mm	mm	mm
5	SM005RB	41	25	28	46	16	8	9	25	50	6	14
10	SM010RB	61	39	42	66	22	10	9	35	69	6	25
15	SM015RB	76	47	42	82	22	11	9	35	69	6	25
23	SM023RB	86	58	57	95	31	14	12	41	84	7	38

Clevis eye piston



	Model	A	B	C	D	E	F	G	H	I
Tn	LARZEP	mm	UN	mm	mm	mm	mm	mm	mm	mm
5	SM005RP	25	3/4"-16	28	14	16	15	5	19	55
10-15	SM010-15RP	28	1"-8	42	25	22	24	7	28	84
15	SM023RP	45	1/2"-16	57	38	31	27	8	35	101

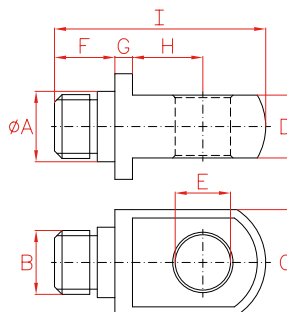

Larzep designs and manufactures special cylinders and fixing systems, upon request.

